



Best Technology
For Your Laboratory

**SMART LABORATORY DRYING
OVEN WITH CIRCULATION FAN
S CLASS**

SMART LABORATORY DRYING OVEN WITH CIRCULATION FAN S CLASS

BF400S



Overview | BF400S

FG laboratory drying ovens have various features, including high precision, repeatability, temperature uniformity, and a wide temperature range (up to 300°C). They are suitable and reliable for temperature control and drying materials in scientific, research, and industrial laboratories.

With their ability to connect to the internet in the cloud space, S-class laboratory ovens provide users with the easiest and most convenient way to monitor and analyze extensive data from any location worldwide.

The BF400S is a 400-Liter forced-air circulation smart laboratory drying oven.

Main features | BF400S

Inner chamber and Heater element container made of stainless steel

The heater element embedded by stainless steel shield

External Case Coated with electrostatic powder paint

Circulation fan system with air channel

Temperature Wide range up to 300°C

Equipped with Error Alarm

High energy efficiency

PT100 sensor

Special benefits | BF400S

HCT (Homogeneous chamber technology)

Temperature stability and reproducibility

Uniformity @ 27 points of chamber

Triple-walled chamber

Fast recovery time

DUAL SAFETY

Class 3.1 independent **temperature safety device** (DIN12880)

Visual and audible temperature alarm

2 PT100 sensors

S class controller

The new generation of smart timer is adjustable up to 999 hours and permanent work capability

A wide range of options for programming and documentation using interfaces, integrated data logger and Software FG SMART MONITOR

All parameters are stored in internal memory for up to 1 year

All parameters are logged even in case of **power failure**

More stability thanks to the **fuzzy controller**

Setting all parameters online/offline

Connect to internet with **Wi-Fi**

ARM series microcontroller

User-friendly calibration

Various temp alarm

Open door alarm

USB port

Special benefits | BF400S

FG SMART MONITOR

Multiplatform application (Android, Linux, IOS, windows, macOS, chromium and ...)

Programming, managing & transferring data by USB flash

Various reports with graphs and tables in pdf/excel format

Unlimited programs, each program up to 100 steps

Weekly, monthly **automatic report** by email

Online controller display lock/unlock

Reports according to **GMP /GLP**

User friendly **online calibration**

Online monitoring and alarms

Temperature ramp setting

SMS/email notification

weekly program

Inner chamber

Silicon tape around the door resistant to temperatures of up to 330°C

Easy access to the element container for cleaning

Easy loading and unloading of specimen material

Circulation fan system with air channel

2 chrome -plated racks included

Fully stainless-steel chamber

Adjustable height of shelves

Rack with tilt protection

Easy cleaning

Special benefits | BF400S

Outer body

Air exchange rates and air flap position electronically controllable

Pre-heated fresh air prevents temperature fluctuations

Very tight door closure with 2-points door latch

Beautiful and ergonomic design

Service and guaranty

10-years after-sales service

5-years heater warranty

2-years guaranty

Specification | BF400S

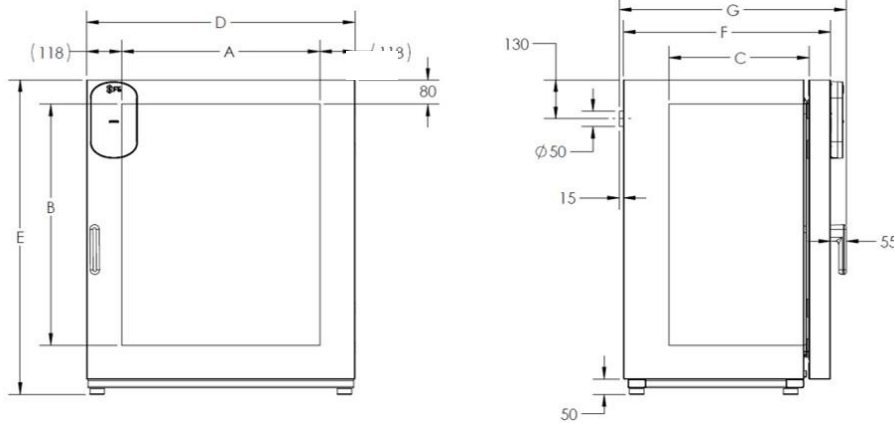

Exterior dimensions

Wall clearance, side (cm)	16
wall clearance, rear (cm)	10
Exhaust duct (outer Ø cm)	5
Depth Plus door handle and controller (cm) (G)	75
Depth without door handle and controller (cm) (F)	69.5
Height (incl. feet) (cm) (E)	106.5
Width (cm) (D)	130
Weight (empty) (kg)	145
Number of doors (ea.)	1

Interior dimensions

Interior volume (l)	400
Height (cm) (B)	82
Width (cm) (A)	106
Depth (cm) (C)	46.3
Permitted total load (kg)	45
Load per rack (kg)	5
Racks number standard (max)	2 (9)
Circulation fan	yes

Specification | BF400S

Temperature data

Temperature range approx. 15 °C above ambient temperature to (°C)	300
Display accuracy (deviation) (±K)	±0.2
Temperature fluctuation @ 80 °C (±K)	±0.5
Temperature fluctuation @ 150 °C (±K)	±1

Uniformity @ 27 points of chamber (variation)

@ 80 °C (±k)	±2
@ 150 °C (±k)	±2.5

Heating-up time *

heating up time to 70 °C (min)	25
heating up time to 150 °C (min)	40
heating up time to 300 °C (min)	70

Specification | BF400S

Recovery time after doors were open for 30 sec *

@ 70 °C (min)	14
@ 150 °C (min)	25
@ 300 °C (min)	40

Electrical data

Power (W)	3100
Frequency (HZ)	50
Voltage (V AC)	220
Current (A)	14
Power type	single phase

* To 98% of the set value

All technical data are specified for units with standard equipment at an ambient temperature of 25 °C and a line voltage fluctuation of $\pm 10\%$.

Options and accessories |BF400S

Additional stainless-steel rack

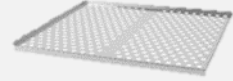

Access port with silicone plug



Metal-framed glass doors



Qualification folder IQ/OQ/PQ



Calibration certificate



Interior lighting



External sensor



Rack



Door lock





Email: info@fginst.com
Website: www.fginst.com