



Best Technology
For Your Laboratory

**SMART HOT INCUBATOR
WITH NATURAL CONVECTION
S CLASS**

SMART HOT INCUBATOR WITH NATURAL CONVECTION S CLASS

CM55S



Overview | CM55S

FG Incubators are equipped with various features, including high precision, repeatability, and temperature uniformity, making them suitable and reliable for the growth of microorganisms and creating a constant temperature environment in scientific, research, and industrial laboratories.

S-class incubators, with their ability to connect to the internet in the cloud space, provide users with the easiest and most convenient way to monitor and analyze extensive data from any location worldwide.

The CM55S is a 55-Liter natural convection smart incubator.

Main features | CM55S

Inner chamber and Heater element container made of stainless steel

The heater element embedded by stainless steel shield

External Case Coated with electrostatic powder paint

Inner door made of tempered safety glass

Equipped with Error Alarm

High energy efficiency

PT100 sensor

Special benefits | CM55S

HCT (Homogeneous chamber technology)

Temperature stability and reproducibility

Uniformity @ 27 points of chamber

Triple-walled chamber

Fast recovery time

DUAL SAFETY

Class 3.1 independent **temperature safety device** (DIN12880)

Visual and audible temperature alarm

2 PT100 sensors

S class controller

The new generation of smart timer is adjustable up to 999 hours and permanent work capability

A wide range of options for programming and documentation using interfaces, integrated data logger and Software FG SMART MONITOR

All parameters are stored in internal memory up to 1 year

All parameters logged even in case of **power failure**

More stability thanks to the **fuzzy controller**

Setting all parameters online/offline

Connect to internet with **Wi-Fi**

ARM series microcontroller

User-friendly calibration

Various temp alarm

Open door alarm

USB port

Special benefits | CM55S

FG SMART MONITOR

Multiplatform application (Android, Linux, IOS, windows, macOS, chromium and ...)

Programming, managing & transferring data by USB flash

Various reports with graphs and tables in pdf/excel format

Unlimited programs, each program up to 100 steps

Weekly, monthly **automatic report** by email

Online controller display lock/unlock

Reports according to **GMP /GLP**

User friendly **online calibration**

Online monitoring and alarms

Temperature ramp setting

SMS/email notification

weekly program

Inner chamber

Silicon tape around the door resistant to temperatures of up to 320°C

Easy access to the element container for cleaning

Easy loading and unloading of specimen material

Circulation fan system with air channel

2 chrome -plated racks included

Fully stainless-steel chamber

Adjustable height of shelves

Rack with tilt protection

Easy cleaning

Special benefits | CM55S

Outer body

Air exchange rates and air flap position electronically controllable

Pre-heated fresh air prevents temperature fluctuations

Very tight door closure with 2-points door latch

Beautiful and ergonomic design

Service and guaranty

10-years after-sales service

5-years heater warranty

2-years guaranty

Specification | CM55S

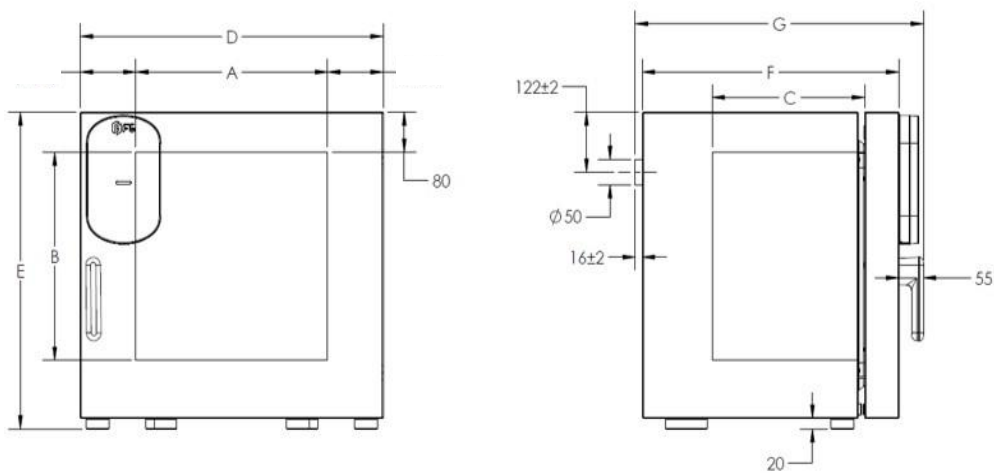

Exterior dimensions

Wall clearance, side (cm)	16
Wall clearance, rear (cm)	10
Exhaust duct (outer \varnothing cm)	5
Depth Plus door handle and controller (cm) (G)	60
Depth without door handle and controller (cm) (F)	54.5
Height (incl. feet) (cm) (E)	63.5
Width (cm) (D)	64.5
Weight (empty) (kg)	43
Number of doors (ea.)	1
Number of interior glass doors (ea.)	1

Interior dimensions

Interior volume (l)	50
Height (cm) (B)	41.5
Width (cm) (A)	41
Depth (cm) (C)	29.5
Permitted total load (kg)	60
Load per rack (kg)	30
Racks number standard (max)	2 (4)
Circulation fan	No

Specification | CM55S

Temperature data

Temperature range approx. 5 °C above ambient temperature to (°C)	80
Display accuracy (deviation) @ 37°C (±K)	±0.2
Display accuracy (deviation) @ 55°C (±K)	±0.2
Display accuracy (deviation) @ 70°C (±K)	±0.1
Temperature fluctuation @ 37°C (±K)	±0.2
Temperature fluctuation @ 55°C (±K)	±0.2
Temperature fluctuation @ 70°C (±K)	±0.2
Setting temperature accuracy	±0.1

Uniformity @ 27 points of chamber (variation)

@ 37°C (±k)	±0.5
@ 55°C (±k)	±0.6
@ 70°C (±k)	±0.7

Heating-up time *

Heating up time to 37°C (min)	55
Heating up time to 55°C (min)	95
Heating up time to 70°C (min)	100

Recovery time after doors were open for 30 sec

@ 37°C (min)	35
@ 55°C (min)	35
@ 70°C (min)	40

Specification | CM55S

Electrical data

Power (W)	400
Frequency (HZ)	50
Voltage (V AC)	220
Current (A)	1.8
Power type	single phase
Plug type	CEE 7/7 plug (compatible with E and F)

Electric energy consumption

@ 37°C (Wh/h)	20
@ 55°C (Wh/h)	45
@70°C (Wh/h)	65

Specification | CM55S

Packing/ shipping data

Transport information	Device Must be transported upright
Width incl carton (CM) approx.	74
Height incl carton & pallet underneath (CM) approx.	73
Depth incl carton (CM) approx.	74
Packing Material	Carton
Gross weight with packing (KG) approx.	46

* To 98% of the set value

- All technical data are specified for units with standard equipment at an ambient temperature of 25 °C and a line voltage fluctuation of $\pm 10\%$.
- FG reserves the right to change technical specifications at any time.

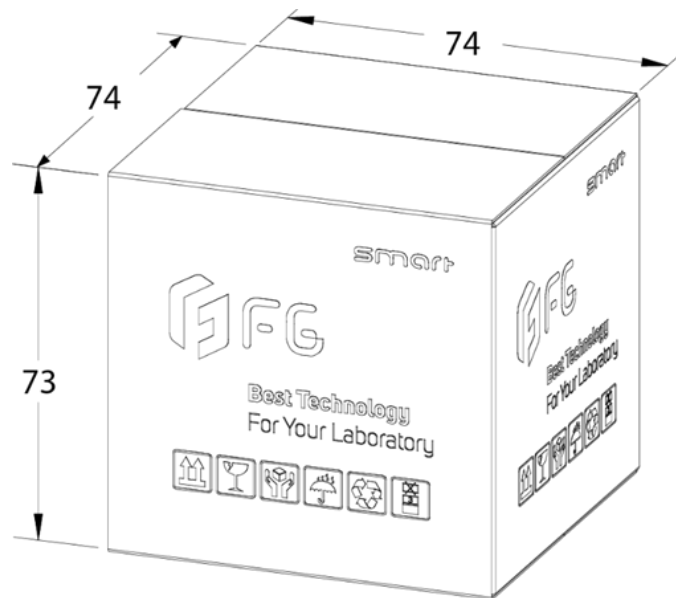

Options and accessories |CM55S

Additional stainless-steel rack

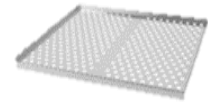

Access port with silicone plug



Metal-framed glass doors



Qualification folder IQ/OQ/PQ



Calibration certificate



Interior lighting



External sensor



Rack



Door lock





Email: info@fginst.com
Website: www.fginst.com